



**WOOSUNG**  
vacuum pump



# WSSR-V SERIES

Rotary piston vacuum pump



# WSSR-V SERIES

1500~7500 Liter/min



## Design Feature

- ▶ 우수한 진공도 및 배기속도
- ▶ 간단한 가스밸러스트 밸브 조정으로 응축성 가스의 작업공정에 용이
- ▶ 컴팩트한 설계
- ▶ 공랭식(적용모델:WSSR-V1.5K)과, 수랭식 냉각방법 적용으로 안정적인 연속운전
- ▶ 저소음 및 저진동
- ▶ 흡입구, 배기구 진공용 플랜지(KSB-1540)규격 적용
- ▶ 간단한 유지보수 및 펌프 수리의 용이

- ▶ Excellent ultimate vacuum and pumping speed.
- ▶ Easy control of gas ballast valve.
- ▶ Simple compact design.
- ▶ Efficient cooling system, air-cooling for WSSR-V1.5K and water-cooling for the rest, for continuous operation.
- ▶ Low vibration level and low noise level.
- ▶ Vacuum flange (KSB-1540) is used for inlet and outlet of pump.
- ▶ Easy maintenance and repairing.

## External pump sketch

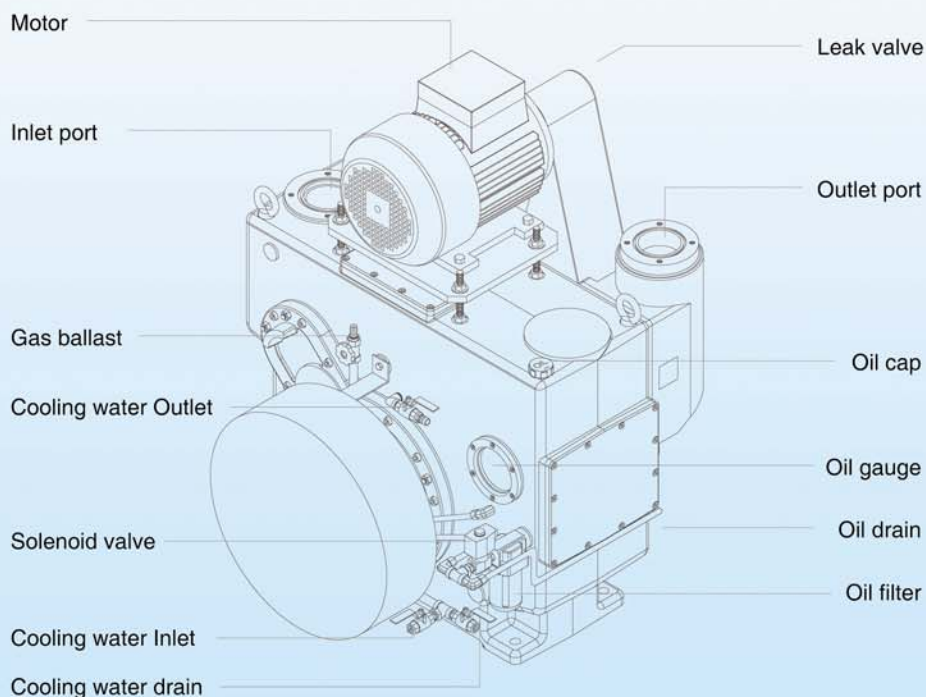



# WSSR-V SERIES

1500~7500 Liter/min

## Technical Data

DESCRIPTION	UNIT	WSSR-V1.5K	WSSR-V2.5K	WSSR-V4.8K	WSSR-V7.5K
Displacement speed	Liter/min	1500	2500	4800	7500
Ultimate pressure	Torr	$5 \times 10^{-3}$	$5 \times 10^{-3}$	$5 \times 10^{-3}$	$5 \times 10^{-3}$
Inlet port		VG50	VG80	VG80	VG100
Outlet port		VG50	VG50	VG65	VG100
Motor power	kW	2.2	3.7	7.5	11
Rotational speed of pump	R.P.M	410	410	410	380
Oil filling	Liter	5	8	17	29
Weight	kg	236	324	555	791
V-Belt	Size/Q'ty	3V-600 / 3	3V-670 / 3	3V-800 / 4	3V-1000 / 6
Cooling water	Liter	-	5	5	7

## Pumping Speed Curve

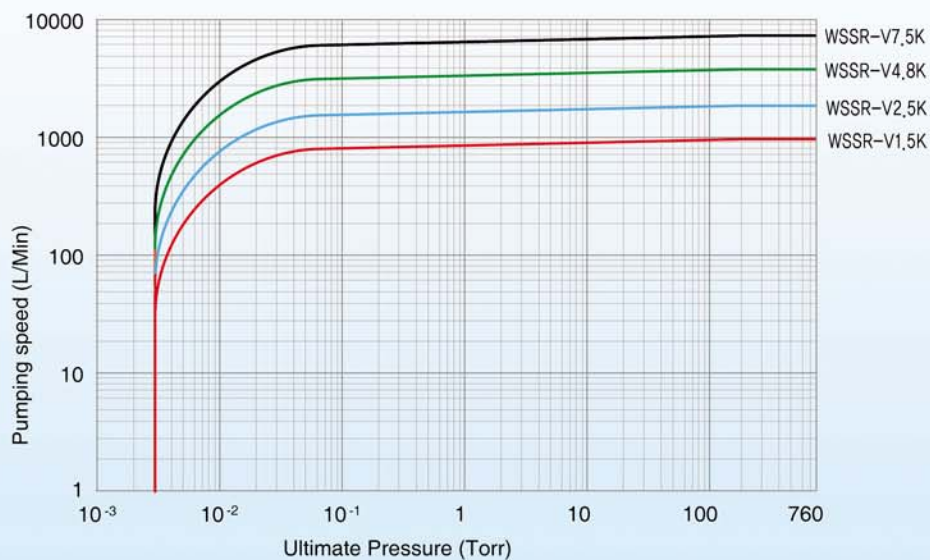

### ※ 주의사항

모든 부품이나 진공오일은 순정품이나 제조자가 추천한 제품을 사용하기 바라며, 만약 불량품을 사용하여 발생한 고장에 대해서는 책임을 지지 않습니다.

### ※ Attention

All spare parts and vacuum oil, which are used for repairing and maintenance, should be genuine or recommended ones by manufacturer.

The company do not take responsibility for the trouble caused from using defective parts or imitations.



# WSSR-V SERIES

1500~7500 Liter/min

## Outside Dimension

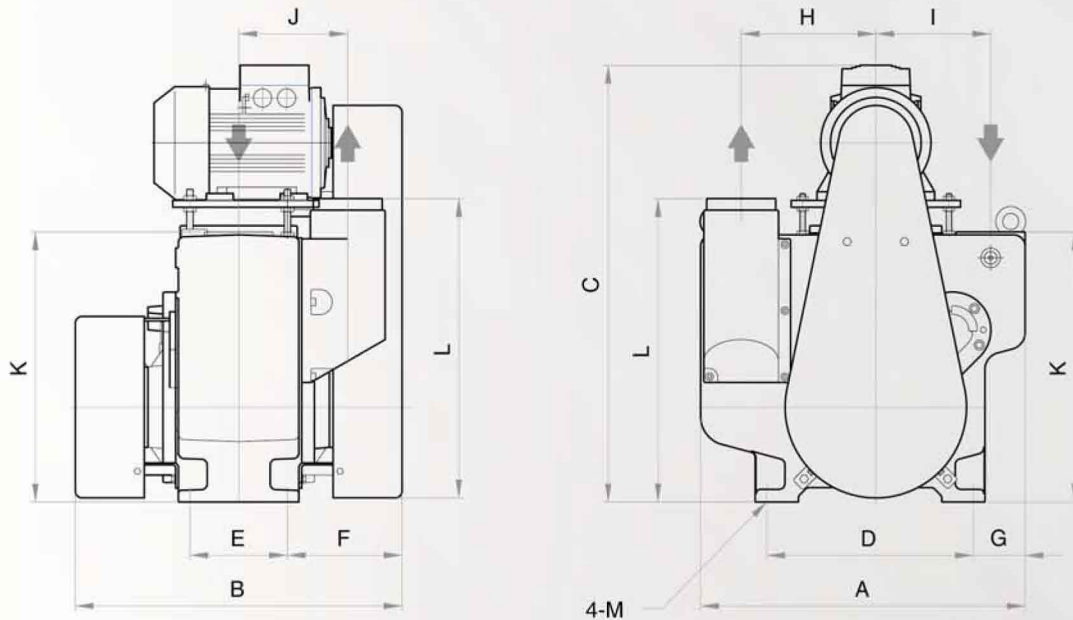

(UNIT:mm)

MODEL	A	B	C	D	E	F	G	H	I	J	K	L	M
WSSR-V1.5K	560	575	760	360	170	206	90	235	200	190	470	530	∅14
WSSR-V2.5K	670	605	815	450	180	216	95	276,5	220	205	515	569	∅20
WSSR-V4.8K	805	740	1035	580	230	260	105	326	290	250	675	750	∅20
WSSR-V7.5K	900	826	1190	670	280	279	125	364	317,5	300	765	857	∅20

## Dimensions of flange

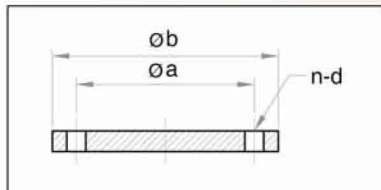

(UNIT:mm)

STANDARD	a	b	n	d
VG50	100	120	4	M8
VG65	120	145	4	M10
VG80	135	160	4	M10
VG100	160	185	8	M10



※ 본사판매  
 경기도 김포시 양촌읍 황금로 258번길 14  
 TEL : 031-432-7324  
 FAX : 031-498-7328  
 홈페이지 : www.vacuumkorea.com

※ Head office  
 14, Hwanggeum-ro 258beon-gil,  
 Yangchon-eup, Gimposi, Gyeonggi-do, Korea  
 TEL : 031-432-7324  
 FAX : 031-498-7328  
 Homepage : www.vacuumkorea.com